

REV.	ECO NUMBER	DESCRIPTION	DATE	APP	ZONE
------	------------	-------------	------	-----	------

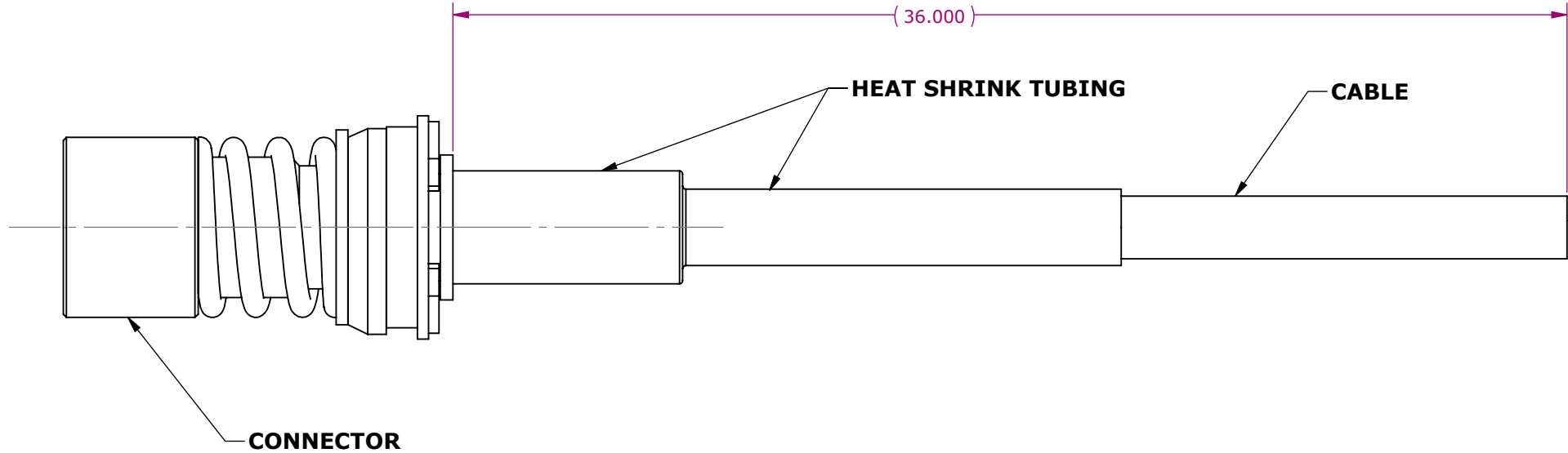

MATERIAL	N/A
HEAT TREAT	N/A
FINISH	N/A
DR.	K.GOLDEN
ECO	N/A
DATE	3/12/25
ASSY	N/A
QUOTE	N/A

DIMENSIONS ARE IN INCH [MM]	
DECIMAL TOLERANCES ARE (UNLESS OTHERWISE SPECIFIED)	
.X ±.03 [.76]	TAPER ON ANY DIA. ≤ .002 [.05]
.XX ±.015 [.38]	CORNER RADII ≤ .005 [.13]
.XXX ±.005 [.13]	SURFACE FINISH 32/
.XXXX ±.0005 [.013]	ANGLES ±2°
THE INFORMATION CONTAINED HEREIN IS DEEMED BY EVERETT CHARLES TECH. INC. TO BE PROPRIETARY AND CONFIDENTIAL AND IS NOT TO BE DUPLICATED OR REPRODUCED OR DISCLOSED TO ANY PERSON OR FIRM EXCEPT AS SPECIFICALLY AUTHORIZED IN WRITING BY EVERETT CHARLES TECH. INC.	
DO NOT SCALE DRAWING	
SCALE	4:1
SHEET	1 OF 1



DESCRIPTION	
FIXTURE SIDE CABLE ASSEMBLY FOR REFERENCE ONLY	
PART NO.	REV
VGf-SMB-36	N/A