

ITEM NO.	PART NUMBER	DESCRIPTION	QTY.
1	A29675	SPECIAL SHOULDER SCREW	2
2	A30279	(Ri) RETAINER RING 5103-12	2
3	923067	SPACER (RCVR BLK - SHOULDER SCREW)	2
4	A32502	ALIGNMENT PIN (RECEIVER BLOCK)	2
5	B32509	RECEIVER BLOCK 15 POSITION FLOAT (VGRCB-15CPF)	1

REV.	DESCRIPTION	DFT	DATE	ECR NO.
A	INITIAL RELEASE	YAN ZHANG	3/18/15	NIL
BA	UPDATE ITEM 4 ADDED RADIO DIMENSION 0.30mm	D.HERNANDEZ	10/7/2016	NIL
CA	CHANGING SPACER PN	S. GARCIA	4/13/2017	
D	ADDED VGRCB-15CPF TO TITLE BLOCK.	K.G.	1/22/2019	1075

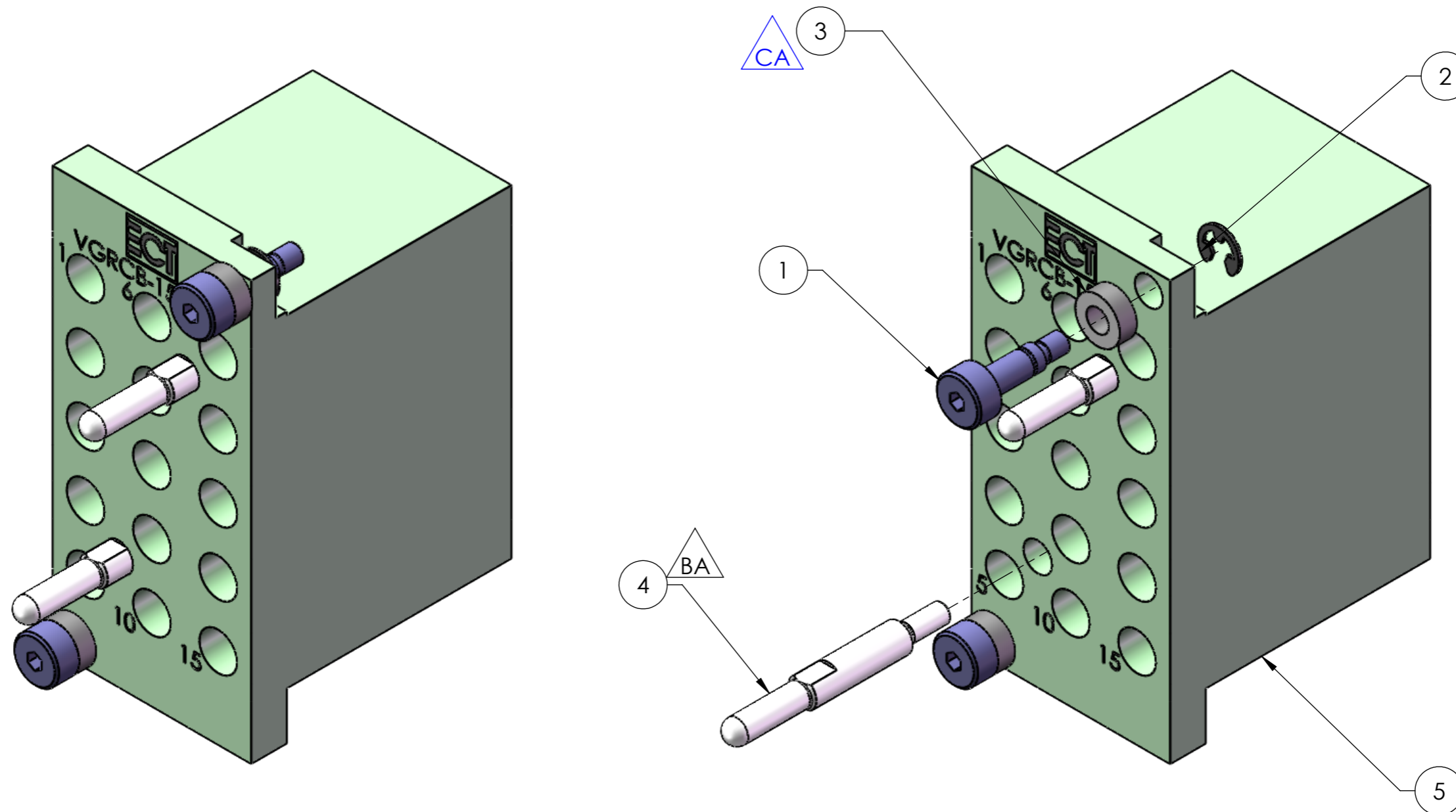

QTY: REFER TO BOM

PLEASE NOTE:
1. DIMENSIONAL LIMITS APPLY AFTER TREATMENT.
2. REMOVE ALL SHARP EDGES.
3. -

THIS DOCUMENT IS THE PROPERTY OF, AND CONTAINS INFORMATION PROPRIETARY TO **EVERETT CHARLES TECHNOLOGIES**. IT IS TO BE RETURNED UPON REQUEST. REPRODUCTION BY ANY MEANS, DISCLOSURE OR USE OF ITS CONTENTS FOR WHICH IT IS LOANED, WITHOUT WRITTEN CONSENT OF EVERETT CHARLES TECHNOLOGIES IS STRICTLY PROHIBITED.

UNLESS OTHERWISE SPECIFIED:
1. DIMENSIONS ARE IN INCHES
2. DEBURR ALL SHARP EDGES: .01 x 45°
3. DO NOT SCALE DRAWING
4. TOLERANCES: .ANGLES ± 0.5°
.XX ± 0.02
.XXX ± 0.005
.XXXX ± 0.0005
5. MACHINING REQUIRED:

PROJECTION:	
DRAWN BY:	YAN ZHANG
ENGR APVD	
MATERIAL	
TREATMENT	



TITLE				
VGRCB-15CPF				
SIZE	SCALE	DOCUMENT NUMBER	SHEET	REV
A4	2:1	910	1 OF 1	D