

ITEM NO.	PART NUMBER	DESCRIPTION	QTY.
1	813499	PIN DOWEL .062 X .250 LONG	2
2	A17173-3	SCREW, SHCS #2-56 X 1/4	2
3	A19304-2	SCR, PAN HD, #4-40 x 0.375", SST	2
4	A31178	ALIGNMENT BUSHING FIXTURE BLOCK	2
5	A31875	BUSHING RETAINER	2
6	B31874	FIXTURE BLOCK	1
7	B31876	CONTACT PLATE 9 POSITION	1
8	A19304-1	SCR, PAN HD, #4-40 x 0.250", SST	2

REV.	DESCRIPTION	DFT	DATE	ECR NO.
A	INITIAL RELEASE	YAN ZHANG	4/19/2015	NIL
B	CHG'D ITEM 2 FROM A17173-1 TO A17173-3		10/30/2018	1064
C	ADDED ITEM 8 (A19304-1) TYP. 2 PLACES AND CHANGED THE QTY ON ITEM 3 TO 2.	K.G.	11/7/2018	1066

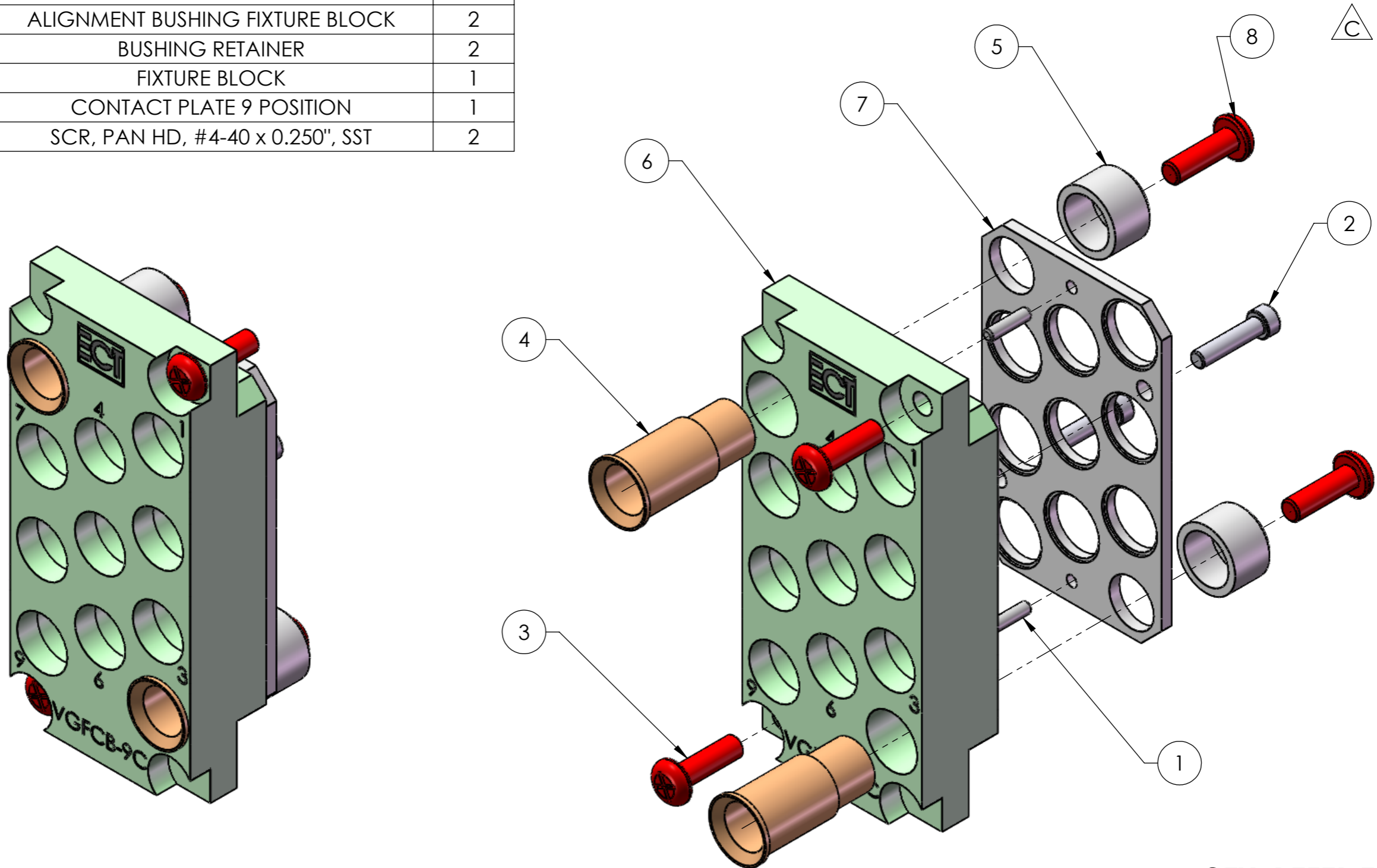

QTY: REFER TO BOM

- PLEASE NOTE:**
1. DIMENSIONAL LIMITS APPLY AFTER TREATMENT.
 2. REMOVE ALL SHARP EDGES.
 3. -

THIS DOCUMENT IS THE PROPERTY OF, AND CONTAINS INFORMATION PROPRIETARY TO **EVERETT CHARLES TECHNOLOGIES**. IT IS TO BE RETURNED UPON REQUEST. REPRODUCTION BY ANY MEANS, DISCLOSURE OR USE OF ITS CONTENTS FOR WHICH IT IS LOANED, WITHOUT WRITTEN CONSENT OF EVERETT CHARLES TECHNOLOGIES IS STRICTLY PROHIBITED.

- UNLESS OTHERWISE SPECIFIED:
1. DIMENSIONS ARE IN INCHES
 2. DEBURR ALL SHARP EDGES: .01 x 45°
 3. DO NOT SCALE DRAWING
 4. TOLERANCES: .ANGLES ± 0.5°
.XX ± 0.02
.XXX ± 0.005
.XXXX ± 0.0005
 5. MACHINING REQUIRED:

PROJECTION:	
DRAWN BY:	YAN ZHANG
ENGR APVD	
MATERIAL	
TREATMENT	



BLK161 KALLANG WAY #06-18/26
SINGAPORE 349247
TEL: (65) 62938966 FAX: (65) 62939866

TITLE		A VGFCB-9CF		
SIZE	SCALE	DOCUMENT NUMBER	SHEET	REV
A4	2:1	1122	1 OF 1	C