

ITEM NO.	PART NUMBER	DESCRIPTION	QTY.
1	SIP-90-2	PIN, SOLID DUMMY, SQ. (.030 LG, HEAD)	85
2	A19304-2	SCR, PAN HD, #4-40 x 0.375", SST	2
3	B10031-S	INTERFACE BLOCK 170 PTS (FOR SQUARE TAILS)	1

REV.	DESCRIPTION	DFT	DATE	ECR NO.
A	INITIAL RELEASE	YAN ZHANG	3/23/2015	NIL
AB	ADDED INSTRUCTION PIN ORIENTATION	D.HERNANDEZ	8/16/2016	NIL
BA	UPDATED THE PIN DIAMETER INTERFACE BLOCK TO 1.55mm	D.HERNANDEZ	10/17/2016	NIL
CA	UPDATE ITEM No. 3	RAFAEL D.	12/19/2016	NIL
D	CHG'D TITLE FROM VGFCB-85 TO VGFCB-85H. CHG'D A12476 TO SIP-90-2.	K.G.	9/4/2018	1049

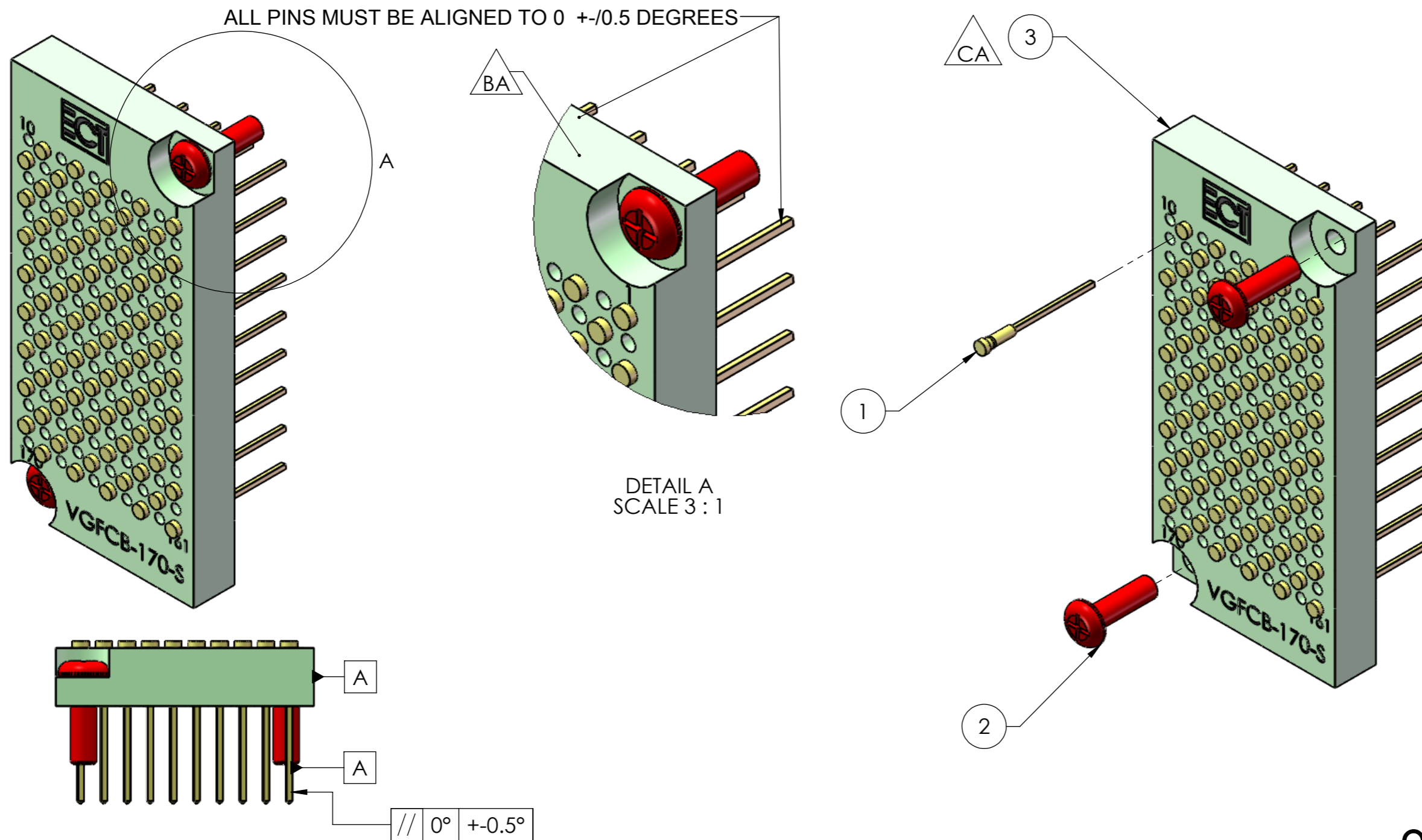

PLEASE NOTE:
1. DIMENSIONAL LIMITS APPLY AFTER TREATMENT.
2. REMOVE ALL SHARP EDGES.
3. -

THIS DOCUMENT IS THE PROPERTY OF, AND CONTAINS INFORMATION PROPRIETARY TO **EVERETT CHARLES TECHNOLOGIES**. IT IS TO BE RETURNED UPON REQUEST. REPRODUCTION BY ANY MEANS, DISCLOSURE OR USE OF ITS CONTENTS FOR WHICH IT IS LOANED, WITHOUT WRITTEN CONSENT OF EVERETT CHARLES TECHNOLOGIES IS STRICTLY PROHIBITED.

UNLESS OTHERWISE SPECIFIED:
1. DIMENSIONS ARE IN INCHES
2. DEBURR ALL SHARP EDGES: .01 x 45°
3. DO NOT SCALE DRAWING
4. TOLERANCES: .ANGLES ± 0.5°
 .XX ± 0.02
 .XXX ± 0.005
 .XXXX ± 0.0005
5. MACHINING REQUIRED:

PROJECTION:	
DRAWN BY:	YAN ZHANG
ENGR APVD	
MATERIAL	
TREATMENT	



BLK161 KALLANG WAY #06-18/26
SINGAPORE 349247
TEL: (65) 62938966 FAX: (65) 62939866

TITLE		A VGFCB-85H		
SIZE	SCALE	DOCUMENT NUMBER	SHEET	REV
A4	2:1	820492	1 OF 1	D

QTY: REFER TO BOM