

ITEM NO.	PART NUMBER	DESCRIPTION	QTY.
1	804987	LABEL ECT UROCAL	1
2	A11734	STOP	4
3	A11735	BUSHING, SLIDE	2
4	A12699-1	SCREW, BHCS 4-40 X 1/4	2
5	A12703-1	SCREW, SHCS #4-40 X 3/8	8
6	700039	SCREW, SHCS #6-32 X 1/2	3
7	A12705-1	SCREW, SHCS #8-32 X 3/8	4
8	A12705-8	SCREW, SHCS #8-32 X 5/8	4
9	A12708-4	SCREW, FHCS #8-32 X 5/8	8
10	A12718-5	DOWEL PIN DIA 3/16 X 3/4	3
11	A12967-3	LOCK WASHER #8	12
12	A17164-2	SCREW, FHCS 4-40 X 0.25	2
13	A17164-4	SCREW, FHCS 4-40 X 0.625	12
14	A17165-1	SCR, PAN HD, #8-32 x 0.375", SST	8
15	A17165-5	SCR, BUTTON, SKT, 1/4"-20 X 0.750, SST	4
16	A19306-3	SCR, PAN HD, #8-32 x 0.625", SST	4
17	A20571	STIFFNER PAD	1
18	A20573	BEARING, ROLLER	2
19	A20574	FLANGED BERING	2
20	A20577	SPACER, FLANGED BEARING	4
21	A35778	PIN, VG RECEIVER ALIGNMENT	4
22	B11725	SLIDE, PLATE (FRONT)	1
23	B11726	SLIDE RCVR RIGHT	1
24	B11730	SUPPORT	1
25	B11756	SLIDE RCVR LEFT	1
26	B20569	CAM	2
27	B20570	CAM SHAFT	1
28	B20572	BLOCK GUIDE	2
29	B20576	HANDLE ALTER	1
30	C11721	PLATE, RECEIVER	1
31	C11722	PLATE, SUPPORT	1
32	C20565	STIFFENER BAR	1
33	C20566	PLATE, SIDE	2
34	C20567	SLIDE, LEFT	1
35	C20568	SLIDE, RIGHT	1
36	C20578	COVER, SUMMATION VGR 24 (VIXI)	1
37	D20563	UPPER CHANNEL	1
38	D20564	LOWER CHANNEL	1

REV.	DESCRIPTION	DFT	DATE	ECR NO.
A	RELEASED PER EDR #622	M RICHARDSON	6/99	-
B	ARTWORK REVISED, MIGRATED TO SW	YAN ZHANG	3/30/2015	5357
CA	CHANGING MPN FROM THE A20574 (THE PREVIOUS ONE IS OBSOLETE), UPDATING B20570& A20577 IN CONSEQUENCE.	S. GARCIA	10/13/2016	

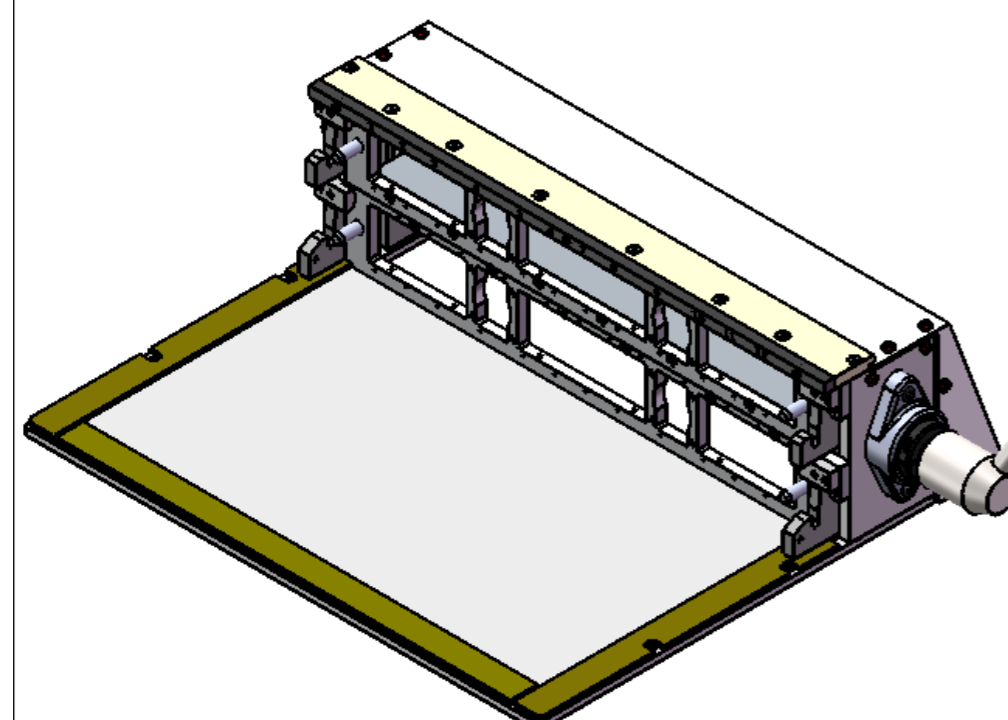
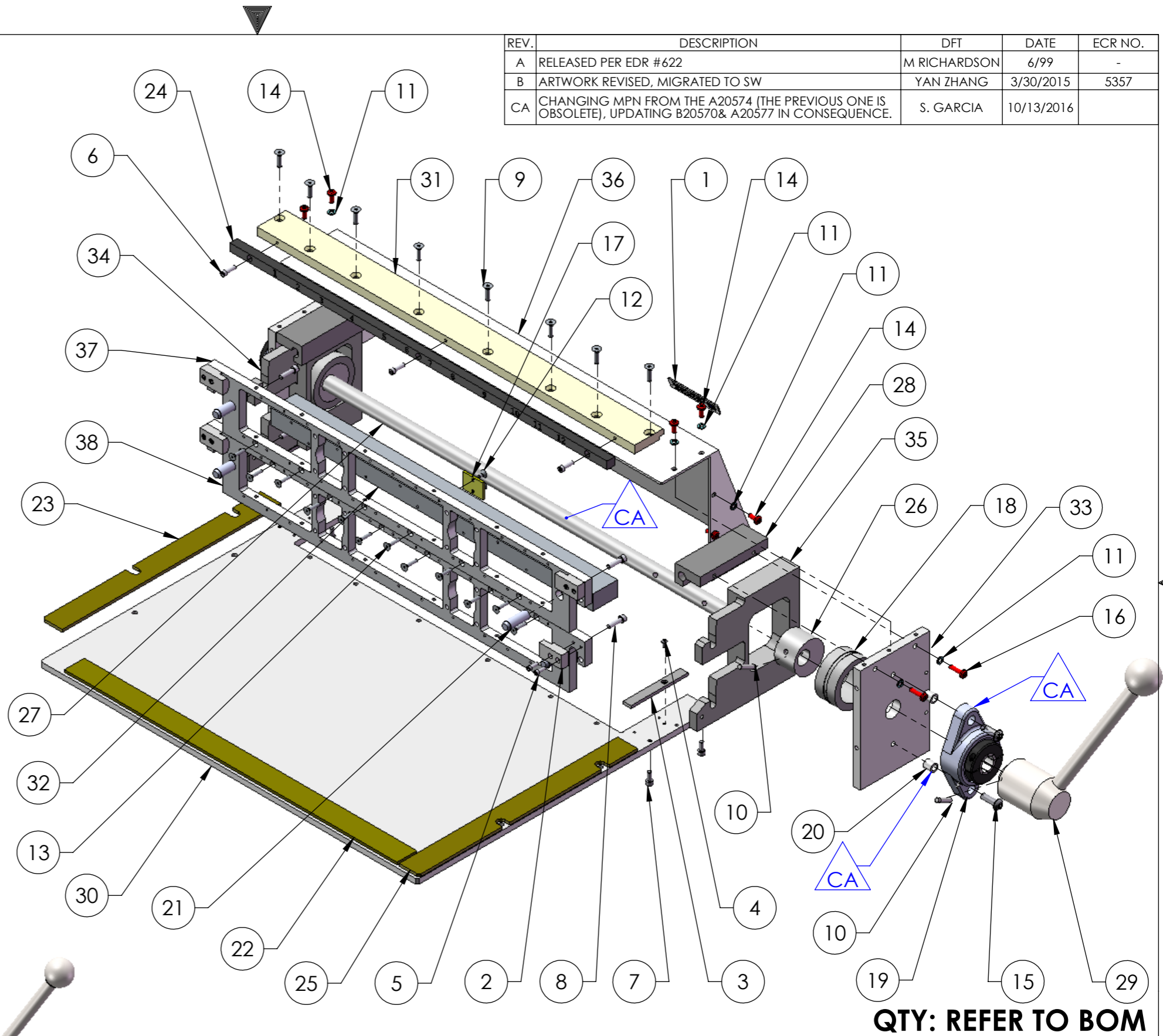

THIS DOCUMENT IS THE PROPERTY OF, AND CONTAINS INFORMATION PROPRIETARY TO EVERETT CHARLES TECHNOLOGIES. IT IS TO BE RETURNED UPON REQUEST. REPRODUCTION BY ANY MEANS, DISCLOSURE OR USE OF ITS CONTENTS FOR WHICH IT IS LOANED, WITHOUT WRITTEN CONSENT OF EVERETT CHARLES TECHNOLOGIES IS STRICTLY PROHIBITED.

UNLESS OTHERWISE SPECIFIED:
 1. DIMENSIONS ARE IN INCHES
 2. DEBURR ALL SHARP EDGES: .01 x 45°
 3. DO NOT SCALE DRAWING
 4. TOLERANCES: .ANGLES ± 0.5°
 .XX ± 0.02
 .XXX ± 0.005
 .XXXX ± 0.0005
 5. MACHINING REQUIRED:

PROJECTION:

DRAWN BY: **YAN ZHANG**

ENGR APVD: _____

MATERIAL: _____

TREATMENT: _____

TITLE: **C (RI) VGR24 BLOCK DESK TOP**

SIZE	SCALE	DOCUMENT NUMBER	SHEET	REV
A4	1:4	207	1 OF 1	CA