

ITEM NO.	PART NUMBER	DESCRIPTION	QTY.
1	700064	WASHER, #4, FLAT, SST, WIDE	2
2	A19304-2	SCR, PAN, PHILIP, #4-40 X 0.375", SST	2
3	A29675	SPECIAL SHOULDER SCREW	2
4	A30279	*(Ri) RETAINER RING 5103-12	2
5	923067	SPACER (RCVR BLK - SHOULDER SCREW)	2
6	A31872	ALIGNMENT PIN RECEIVER BLOCK	2
7	A31879	ALIGNMENT PIN RETAINER	2
8	A32431	A (Ri) AIR FITTING, REC	13
9	B32501	RECEIVER BLOCK 13 POSITION - PNEUMATIC	1

REV.	DESCRIPTION	DFT	DATE	ECR NO.
A	ARTWORK REVISED, MIGRATED TO SW	HARI	12/11/14	5357
BA	UPDATE ECT LOGO	YAN ZHANG	11/11/2015	-
CA	CHANGING SPACER PN	S. GARCIA	4/13/2017	

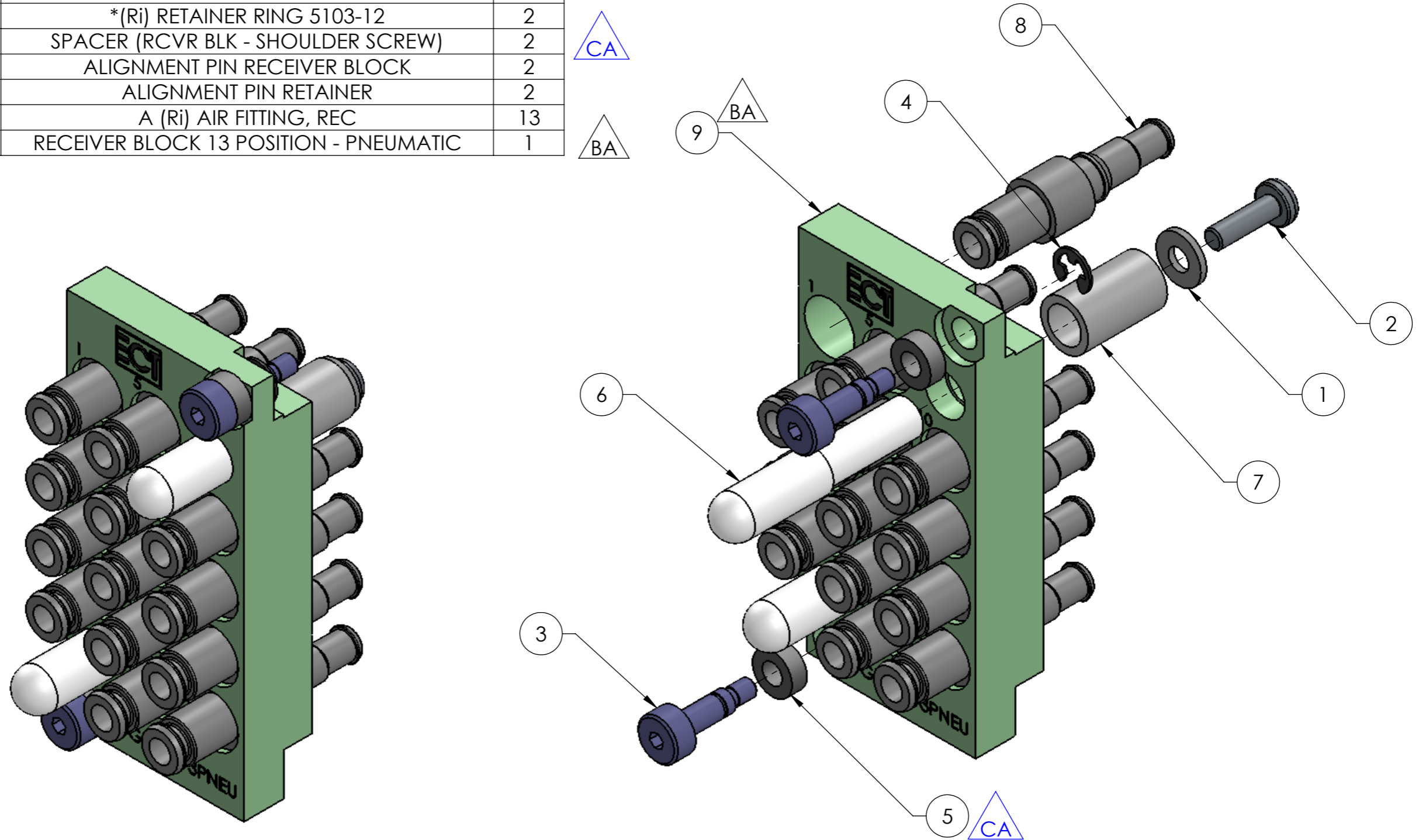

**QTY: REFER TO BOM**

**PLEASE NOTE:**  
 1. DIMENSIONAL LIMITS APPLY AFTER TREATMENT.  
 2. REMOVE ALL SHARP EDGES.  
 3. -

THIS DOCUMENT IS THE PROPERTY OF, AND CONTAINS INFORMATION PROPRIETARY TO **EVERETT CHARLES TECHNOLOGIES**. IT IS TO BE RETURNED UPON REQUEST. REPRODUCTION BY ANY MEANS, DISCLOSURE OR USE OF ITS CONTENTS FOR WHICH IT IS LOANED, WITHOUT WRITTEN CONSENT OF EVERETT CHARLES TECHNOLOGIES IS STRICTLY PROHIBITED.

UNLESS OTHERWISE SPECIFIED:  
 1. DIMENSIONS ARE IN INCHES  
 2. DEBURR ALL SHARP EDGES: .01 x 45°  
 3. DO NOT SCALE DRAWING  
 4. TOLERANCES: .ANGLES ± 0.5°  
 .XX ± 0.02  
 .XXX ± 0.005  
 .XXXX ± 0.0005  
 5. MACHINING REQUIRED:

PROJECTION:	
DRAWN BY:	HARI
ENGR APVD	
MATERIAL	
TREATMENT	



TITLE				
<b>A (RI) VGRCB-13 PNEUMATIC</b>				
SIZE	SCALE	DOCUMENT NUMBER	SHEET	REV
<b>A4</b>		<b>902</b>	<b>1 OF 1</b>	<b>CA</b>